

POWERFLOOD 9 & 18 1.4A

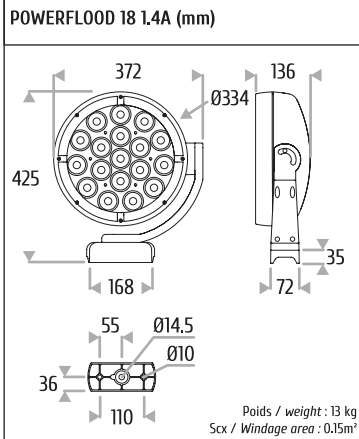

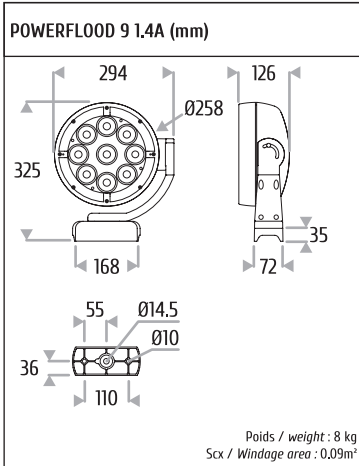

DIMENSIONS



INSTALLATION DU LUMINAIRE LUMINAIRE INSTALLATION

1 - SENS DE MONTAGE MOUNTING DIRECTION

Lors de la fixation du produit,
le placement de l'étrier détermine
la zone d'éclairage
When fixing the product,
the bracket's position determines
the lighting area

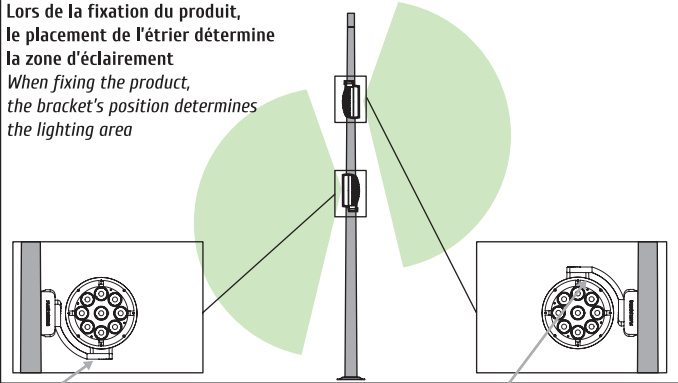

Étrier vers le bas,
éclairage vers la gauche
Bracket directed downwards,
lighting to the left

Étrier vers le haut,
éclairage vers la droite
Bracket directed upwards,
lighting to the right

2 - FIXATION FIXING

PLAN DE PERÇAGE POUR FIXATION DRILLING DRAWING FOR PRODUCT FIXING

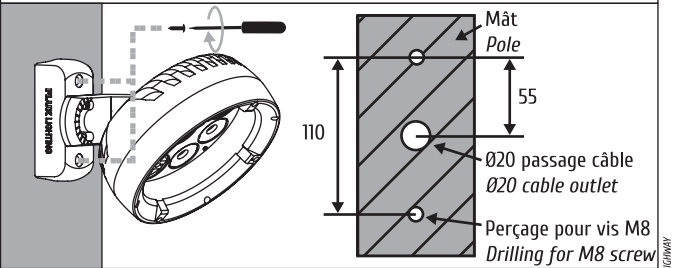

Fixation par deux vis tête fraisée M8x80mm
Fixing with two M8x80mm countersunk screw

3 - RÉGLAGE ADJUSTMENT

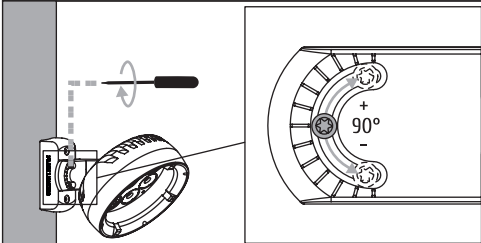

4 - RÉGLAGE ADJUSTMENT

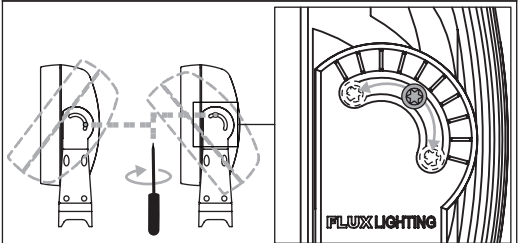

POWERFLOOD 9 & 18 1.4A



ACCESSOIRES

ACCESSORIES

Lentille ovalisante
Elliptical lens

Grille de défilement
Honeycomb louvre

Visière
Glare shield

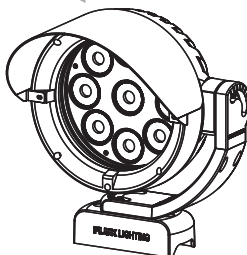
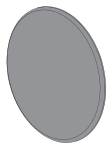

FIXATION VISIÈRE GLARE SHIELD FIXING

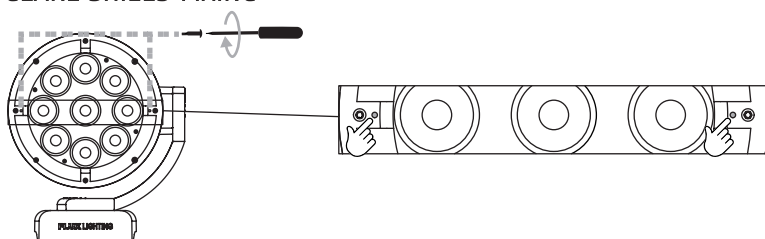

EMPLACEMENT DES ACCESSOIRES POSITION OF ACCESSORIES

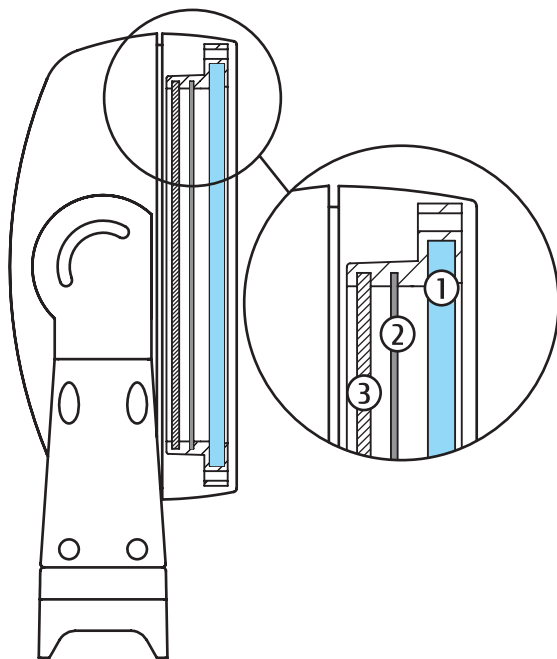

- ① Le verre extra-blanc se positionne dans le joint, au-dessus de tous les accessoires.
The extra-clear glass is placed inside the seal, above all accessories.
- ② La lentille ovalisante est insérée dans le joint sous le verre. Pour la lentille ovalisante, **les stries sont orientées côté LED.**
*Elliptical lens is placed inside the seal, under the glass. For the lens for elliptical lens, **the ridges are facing the LED.***
- ③ La grille de défilement est placée au plus près des optiques.
The honeycombed louvre is closest to the optics.

Emplacements accessoires à titre d'information, ouverture du produit sans autorisation au préalable met fin à la garantie immédiatement.
Positions of accessories for information, opening product without authorization beforehand ends immediately the warranty.



POWERFLOOD 9 : CÂBLAGE AVEC ALIMENTATION DEPORTÉE IP44 CLASSE I POWERFLOOD 9: WIRING WITH REMOTE POWER SUPPLY IP44 CLASS I

COFFRET ALIMENTATION DEPORTÉE 52W SIMPLE ET DOUBLE
SINGLE & DOUBLE REMOTE 52W POWER SUPPLY BOX

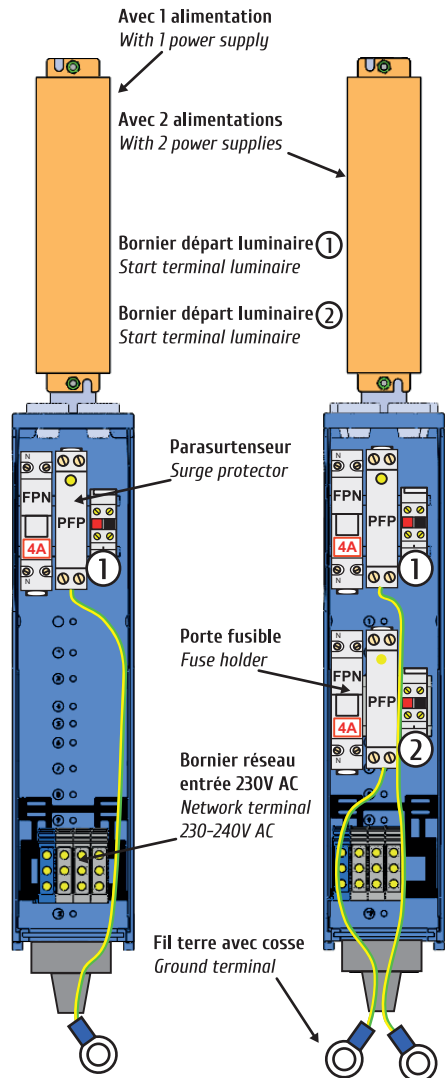
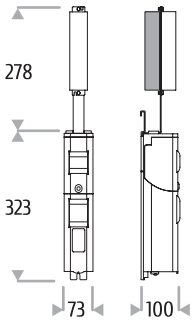

Option : auto-dimming control intégré, jusqu'à 10 seuils max.
Option: auto-dimming control integrated, max. 10 steps



POWERFLOOD 9 & 18 1.4A

POWERFLOOD 18 : CÂBLAGE AVEC ALIMENTATION DEPORTÉE IP44 CLASSE I POWERFLOOD 18: WIRING WITH REMOTE POWER SUPPLY IP44 CLASS I

COFFRET ALIMENTATION DEPORTEE 85W SIMPLE ET DOUBLE
SINGLE & DOUBLE REMOTE 85W POWER SUPPLY BOX

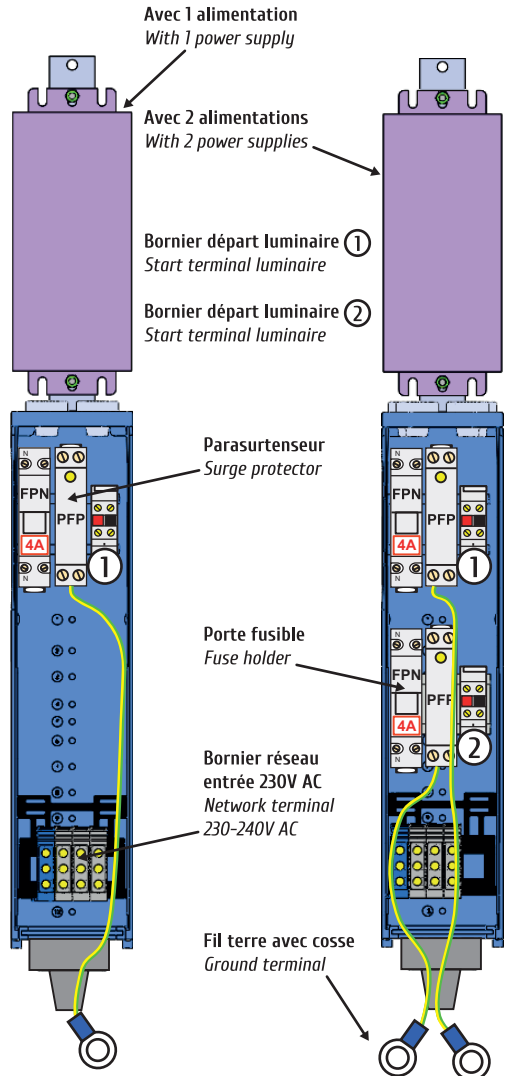
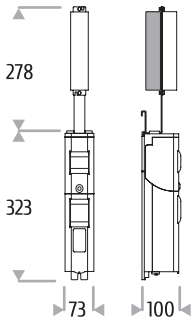

Option : auto-dimming control intégré, jusqu'à 10 seuils max.
Option: auto-dimming control integrated, max. 10 steps



POWERFLOOD 9 : CÂBLAGE AVEC ALIMENTATION DEPORTÉE DALI IP44 CLASSE I POWERFLOOD 9: WIRING WITH REMOTE DALI POWER SUPPLY IP44 CLASS I

COFFRET ALIMENTATION DEPORTÉE DALI 75W SIMPLE ET DOUBLE
SINGLE & DOUBLE REMOTE 75W DALI POWER SUPPLY BOX

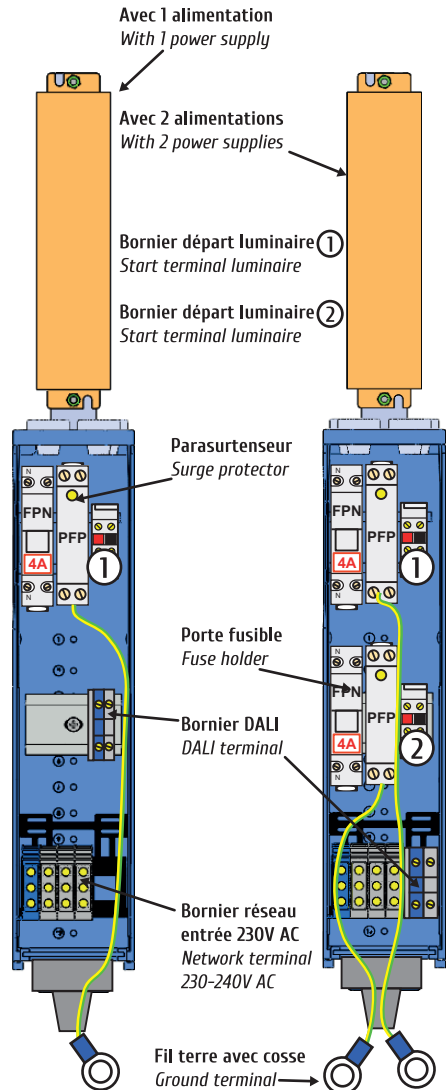
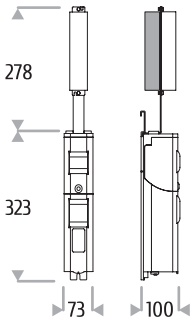

Option : auto-dimming control intégré, jusqu'à 10 seuils max.
Option: auto-dimming control integrated, max. 10 steps



POWERFLOOD 18 : CÂBLAGE AVEC ALIMENTATION DEPORTÉE DALI IP44 CLASSE I POWERFLOOD 18: WIRING WITH REMOTE DALI POWER SUPPLY IP44 CLASS I

COFFRET ALIMENTATION DEPORTÉE 100W SIMPLE ET DOUBLE
SINGLE & DOUBLE REMOTE 100W DALI POWER SUPPLY BOX

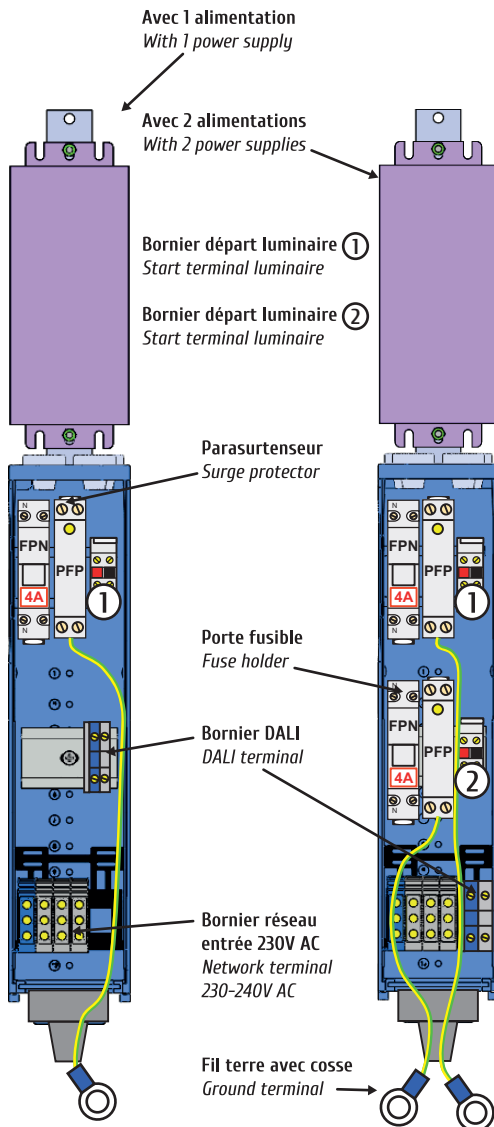
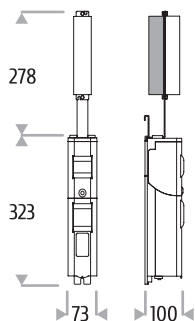

Option : auto-dimming control intégré, jusqu'à 10 seuils max.
Option: auto-dimming control integrated, max. 10 steps



POWERFLOOD 9 & 18 1.4A

PRECONISATIONS RECOMMENDATIONS

INSTALLATION

- Le matériel doit être installé par un professionnel.
- Le fabricant décline toute responsabilité résultant d'une mise en oeuvre inappropriée du produit.

- Toutes modifications apportées au luminaire mettent immédiatement fin à la garantie.

- Câblage : Ne pas écraser ou étirer les câbles. Respecter les codes couleurs et les polarités (voir schéma de câblage).

- Effectuer des raccordements étanches.

 - Effectuer les branchements hors tension.

- Sortir le produit de son emballage.

- Respecter les quantités maximum de produit par alimentation et/ou par sortie.

AVERTISSEMENTS

- Ne pas mettre le luminaire en contact avec des substances corrosives (vérifier la nature des matériaux de l'installation).

- Limiter l'utilisation de produits chimiques de nettoyage aux abords de l'appareil.

- L'appareil d'éclairage ne doit être en aucun cas recouvert par des éléments calorifuges ou par des matériaux semblables.

- Ne jamais ouvrir le luminaire.

ENTRETIEN

- L'entretien du luminaire se fait hors tension.

- Nettoyer la surface régulièrement, afin d'éviter le dépôt de salissure.

- Utiliser des chiffons doux, propres et secs.

- Ne pas nettoyer le luminaire à jets haute pression.

- Ne jamais utiliser de solution chlorée.

INSTALLATION

- The fixtures must be installed by a professional.

- The manufacturer disclaims all responsibility resulting from an inadequate installation of the product.

- Any changes to the luminaire shall immediately terminate the guarantee

- Cabling: do not recess or stretch the cables.

Observe colour codes & polarities (see the wiring diagram).

- Make waterproof connections.

 - Do the connection with the main electrical power supply switched off.

- Remove the luminaire from its packaging.

- Observe the maximum quantities of luminaire by power supply &/ or per outputs.

WARNING

- Don't put the luminaire in contact with corrosive substances (check the materials on the installation).

- Limit the use of cleaning chemicals near of the device.

- The luminaire must not be covered by/or recessed in insulated elements or any similar materials.

- Never open the luminaire.

CLEANING

- Cleaning of the luminaire must be done while power is off.

- Please clean the surface regularly in order to avoid sustainable dirt deposit.

- Use soft sponges & duster.

- Don't clean the luminaire with high-pressure jets.

- Never use a chlorine solution.

FLUX LIGHTING

FRANCE

ZAC de Chesnes Nord

6 rue de Brisson

F-38290 SATOLAS-ET-BONCE

T. +33 (0)4 26 38 91 91

F. +33 (0)4 26 38 91 90

info.flux-lighting.com

www.flux-lighting.com